

## Product Overview

This solid-state AOTF is an electronically tunable bandpass filter for VIS range (400-650 nm). It uses the acousto-optic interaction inside an anisotropic medium (TeO<sub>2</sub>-S) and allows the selection and transmission of several wavelengths from an incoming laser source.

The main advantage of this technique is the total absence of any moving part which leads to a reliable, stable and fast technique for wavelength tuning. The RF frequency applied on the AOTF transducer controls the amplitude of transmitted (filtered in 1st order) wavelength. A complete spectrum analysis can be done by varying the frequency corresponding to the wavelength range.

The Main applications are Confocal microscopy, life science imaging and many others.



## Features

- Multiline operation
- High colinearity in 1st order
- 405 nm operation
- High separation angle between orders 0-1
- High power stability / Pointing stability, Temperature stabilized

	AOTF-A3-400.650-LR7-TN	AOTF-A3.5-400.650-MR7-TN
Material-Acoustic mode-Velocity	TeO <sub>2</sub> - [S] - 660 m/s	
Number of lines (simultaneously or independently)	2	4
Optical Wavelength range	400-650 nm	
Optical Transmission	> 90%	
Input / Output Polarization	Linear ⊥ - Linear //	
Active Aperture	3 x 3 mm <sup>2</sup>	3.5 x 3.5 mm <sup>2</sup>
Drive Frequency	74-158 MHz	
Optical Extinction Ratio	>50 dB	
Rise / Fall time	1 μs / mm,	
Diffraction Efficiency	> 90 %	
Total Field of View (FOV)	2°	
Separation Angle	≥ 4°	
Chromatic Colinearity	≤ 0.3 mrad	
Spectral Resolution (FWHM)	4 nm @ 400nm, 10 nm @ 550 nm, 16 nm @ 650 nm	2nm @ 400nm, 5nm @550nm, 8 nm @ 650 nm
Max optical power density	5 W/mm <sup>2</sup> @532nm (wavelength dependent)	
Temperature stabilization	Type TN (SMC connector)	
Input impedance	Nom 50 Ω	
V.S.W.R.	Nom < 1.2/1	
RF Power per line / Connector	< 0.5 W / SMA (RF)	< 0.3 W / SMA (RF)
Size / Weight	(LxHxh) 70 x 36.6 x 35.8 / 75 g IN PRO 151	
Operating Temperature	+10 to +40 Non condensing	

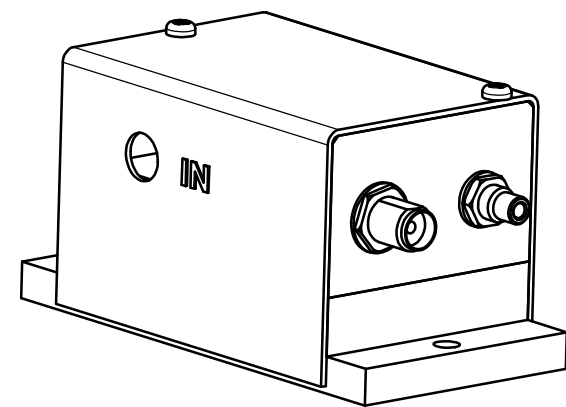

2 Holes  $\varnothing 3,5$   
Through

Bragg Angle Adjust  
 $\varnothing 2,5^{+0,05}$   
 $+0,01$   
Depth 5mm Maxi

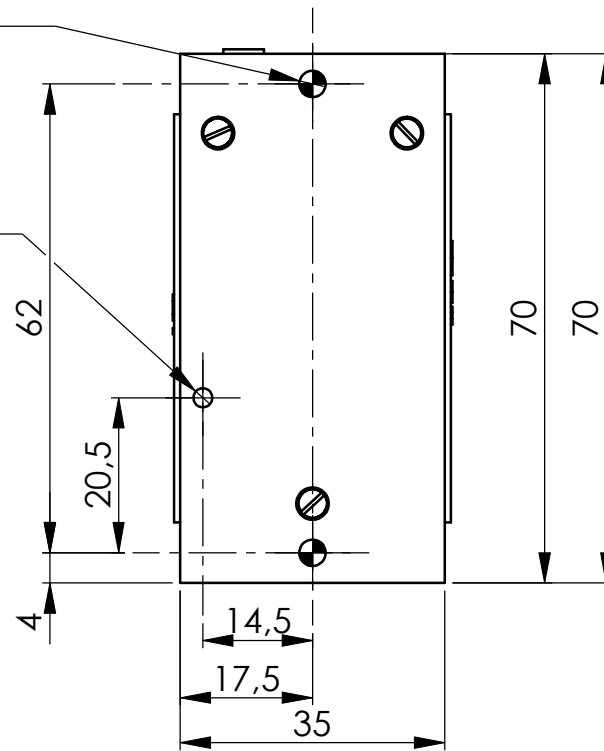

SMA Connector  
RF Input

SMC Connector  
Thermal regulation supply

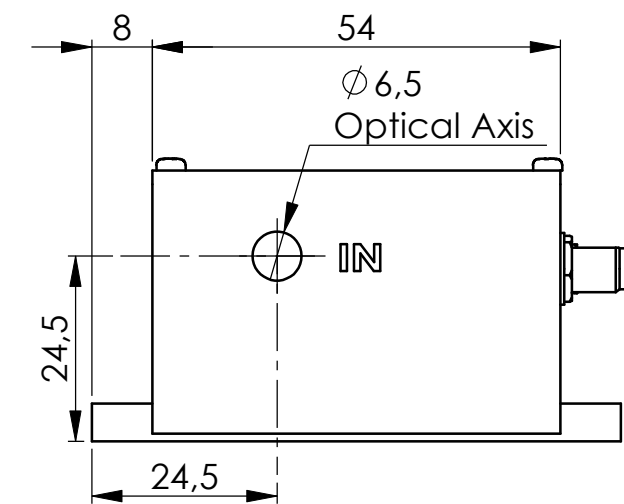
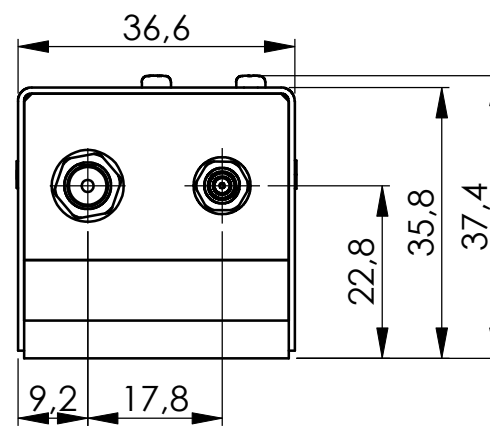
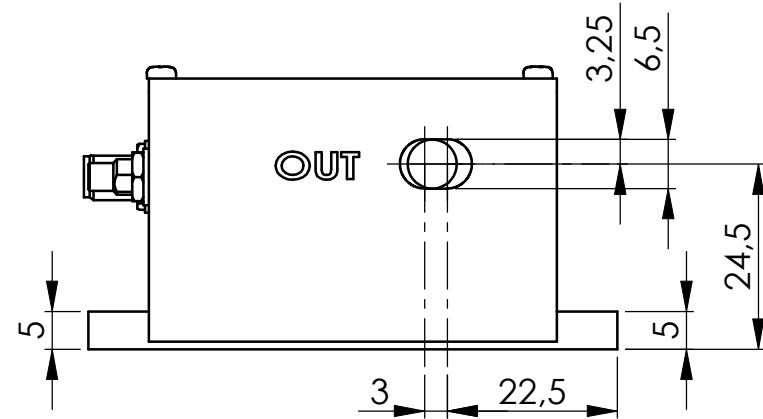
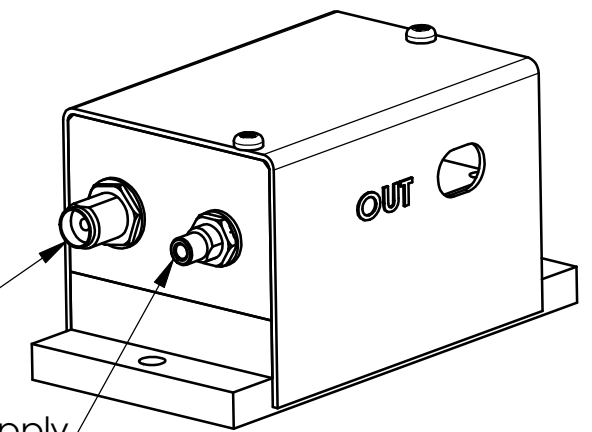

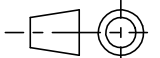
A	15/05/07	E.D	Plan initial / Initial Drawing	
Indice Index	Date	Auteur Author	Modifications	
Conception Design	E.D	PLAN D'INTERFACE / OUTLINE DRAWING		 A.A. SA OPTO-ELECTRONIQUE DIVISION 18, rue Nicolas Appert F-91898 ORSAY tel : 08 11 09 76 76 fax : 01 76 91 50 31
Vérification Checking	L.F			
Tolérance Tolerance	ISO 2768mK	Référence / Reference		
Echelle Scale	1:1	IN-PRO-151		
		Format A3	Ce document est la propriété de A.A.S.A. Il est strictement interdit de reproduire ce document ou une partie sans l'autorisation de A.A.S.A. This document is the property of A.A.S.A. It is strictly prohibited to reproduce this document or a part without the authorization of A.A.S.A.	
			Folio / Sheet 1/1	Indice / Index A