

Product Overview

AA OPTO-ELECTRONIC proposes two types of variable frequency drivers.

VCOs (Voltage Controlled Oscillators) are analog devices and are suitable for general purpose applications (raster scan, or random access...). The VCO can be modulated (amplitude) from an analog external signal. The frequency is externally controlled by an analog signal. An external power amplifier will be required to generate the RF power levels required by the AO device.

DDS (Direct Digital Synthesizers) models offer high frequency accuracy and stability and extremely fast switching times less than 100ns. They will be preferred to VCOs when high stability and accuracy is necessary. They can be modulated (amplitude) from an analog or digital external signal. The frequency is externally controlled by a digital signal (15 to 31 bits). An external power amplifier will be required to generate the RF power levels required by the AO device.



DDSPAxX

Based on DDS (Direct Digital Synthesizers)

These Direct Digital Synthesizers are dedicated to high accuracy applications for which high resolution is the key factor. A PC interface board will be used to control the frequency (15-31 bits) as well as the latch of the frequency (1 bit E/D). These drivers are used in combination with AA amplifiers. They are suitable for agile frequency shifters and deflectors.

Features

- Variable frequency [10..400MHz]
- AM control (Analog or TTL) – High stability
- FM control (Analog) – High Resolution
- Rack available with 2 outputs (XY deflection, Common REF)
- RoHS



DRFAxx

Based on VCO (Voltage Controlled Oscillators)

These Voltage Controlled Oscillators are the simplest way to control a deflector or a variable frequency shifter, in random access or raster scan mode.

A voltage between 0 and 10V is applied on the frequency control input for sweeping between Fmin and Fmax and here the sweeping time can as low as 1µs. The typical stability of the VCO driver is 50 to 100 KHz/°C. For sharpest application, the DDS driver will be preferred. These drivers need to be associated with AA amplifiers (OEM version only).

Features

- Variable frequency [10..400MHz]
- AM control (Analog)
- FM control (Analog)
- Rack available with 2 outputs (XY deflection)
- RoHS



Technical Specifications DDSPA

Parameter	Units	DDSPAxX
Carrier frequency	MHz	10 to 400
Frequency Stability	ppm/°C	Nom +/- 1
Frequency step / Accuracy	KHz/Hz	LR: 15.259 KHz (15 bits) MR: 59.6 Hz (23 bits) HR: 0.23 Hz (31 bits)
Commutation/sweeping time	ns	≤ 40 (LR) - ≤ 64 (MR) - ≤ 80 (HR)
Output RF Power (@1dB compression)	dBm	Nom – 30 to 0 (to be associated with AA Amplifier)
Power supply	VDC VAC	24, nom 0.25A (OEM version) 110-230, Laboratory version
Frequency Input Control	Digital	Digital 15 bits (LR), 23 bits (MR), 31 bits (HR) + 1 bit Enable/disable
Modulation Input Control AM	V	Analog 0-5 / 50 Ω Option 8 bits digital (256 levels)
Rise Time / Fall time (10-90%)	ns	Nom 10
Harmonics	dBc	H2 > 30, H3 > 20
Input / Output impedance	Ω	50
VSWR		< 1.2/1
Extinction Ratio	dB	Nom 45 (for F<250MHz) Option High extinction on request
Input / Output Connectors		HD44 / SMA (OEM)
Size / Weight		OEM: 129 x 61 x 28 mm3 (OEM) / 275 g Lab version: 19", 2U nom 4 Kgs (Lab version)
Heat Exchange		Conduction through baseplate for OEM version
Operating Temperature	°C	10 to 40 (max Tcase 50, OEM version)
Storage Temperature	°C	-40 to +70 Non condensing
PHASE LOCKED Versions		Option: 2 DDS outputs with common Reference for high stability frequency difference



Technical Specifications DRFAxX

Parameter	Units	DRFAxX
Carrier frequency	MHz	Up to one octave 40-100, 60-150, 80-200, 140-300, 190-350 Matched to AO device at factory
Frequency Stability	KHz/°C	Nom +/- 50 to 100 C
Frequency step / Accuracy	ppm	Continuous / typ 50
Commutation/sweeping time	µs	≤ 1 (from Fmin to Fmax or Fmax to Fmin)
Output RF Power (@1dB compression)	dBm	Nom – 30 to 0 (to be associated with AA Amplifier)
Power supply	VDC VAC	24, nom 0.15A (OEM version) 110-230 (Laboratory version)
Frequency Input Control	V	Analog 0-10 / 1kΩ (linearity Nom +/- 5 %)
Modulation Input Control AM	V	Analog 0-5 / 50 Ω
Rise Time / Fall time (10-90%)	ns	Nom 10
Harmonics	dBc	Nom > 20
Input / Output impedance	Ω	50
VSWR		< 1.5/1
Extinction Ratio	dB	nom 45 Option High Extinction on request
Input / Output Connectors		SMA / SMA
Size / Weight		OEM: 84 x 69 x 15.8 mm ³ / 150 g Lab version: 310 x 250 x 105 mm ³ / 3.8 Kg
Heat Exchange		Conduction through baseplate for OEM version
Operating Temperature	°C	10 to 40 (max Tcase 50 for OEM version)
Storage Temperature	°C	-40 to +70 Non condensing
Laboratory version		For laboratory version, the frequency source + the convenient amplifiers are integrated in a box supplied with 110-230 VAC. A switch on the front panel allows the user to select both operating modes: CW mode: internal CW modulation of RF power with front panel cursor EXT mode: external amplitude modulation controlled through external modulation input



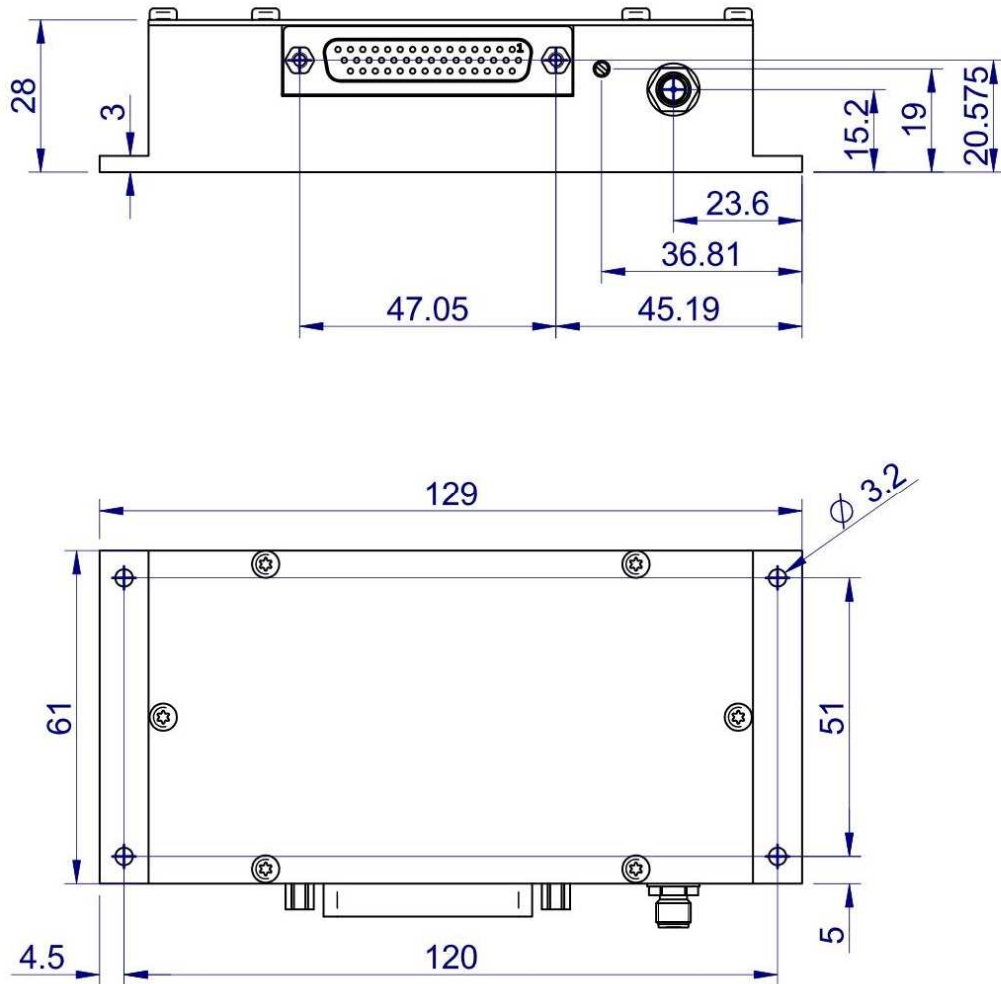

DDSPAxx (OEM version), mm

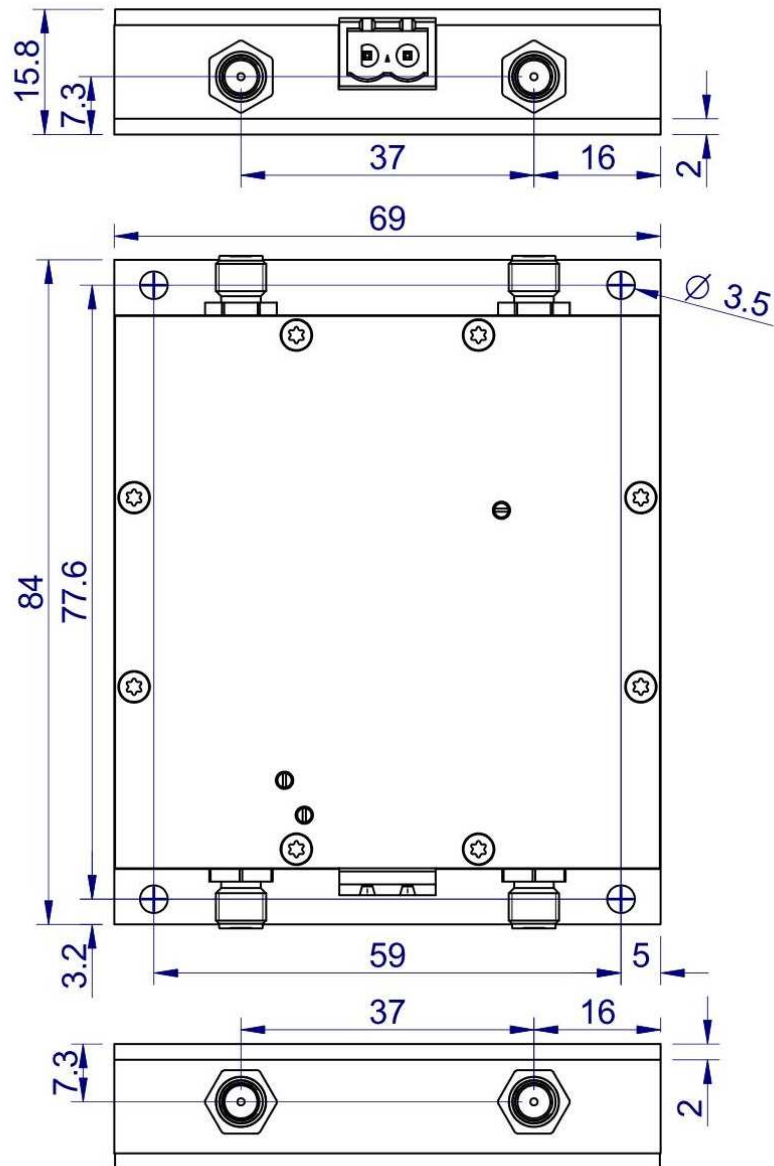

DRFAxx (OEM version), mm